

1999-Newer Ford SVO Plumbing

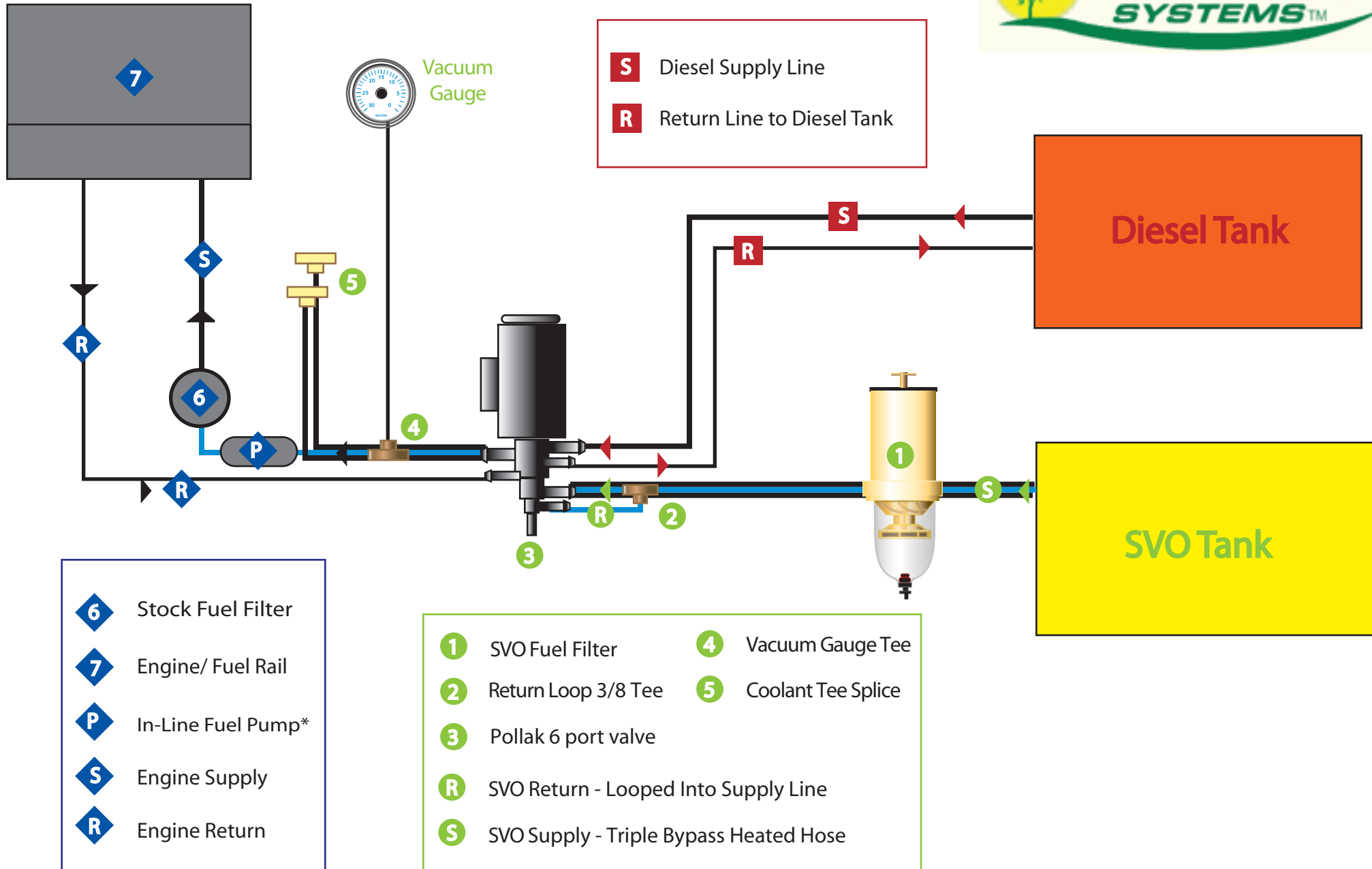

S Diesel Supply Line
R Return Line to Diesel Tank

6 Stock Fuel Filter
7 Engine/ Fuel Rail
P In-Line Fuel Pump*
S Engine Supply
R Engine Return

1 SVO Fuel Filter
2 Return Loop 3/8 Tee
3 Pollak 6 port valve
4 Vacuum Gauge Tee
5 Coolant Tee Splice

R SVO Return - Looped Into Supply Line
S SVO Supply - Triple Bypass Heated Hose

*This is a High-pressure pump (more than 60 psi.) The Pollak 6-Port Switching Valve must be mounted on the suction side of this pump.

*This Stock pump has a life-expectancy of 180,000-220,000 miles. When it fails, please replace it with a FASS SVO HPFP for the best performance on diesel and SVO. If the Vacuum Gauge reads high vacuum on diesel (10+ in Hg) this will cause undue stress on the lift pump. To remedy this restrictions, drop the stock tank and completely remove(do not replace) the Inline Stock Fuel Filters (cigarette sized filters) in the Fuel Pick-up Tube. These cause massive restriction and can take out pumps very quickly.