

- ① Fuel Pump (located in-tank)
- ② Diesel Supply IN stock fuel filter
- ③ Diesel Supply OUT stock fuel filter to supply valve
- ④ Tandem Pump IN (on the top)
- ⑤ RETRUN from Tandem Pump (on the bottom)
- ⑥ Fuel Temperature Sensor
- ⑦ RETURN In- fuel filter
- ⑧ RETURN Out- fuel filter to stock tank
- ⑨ RETURN back to the tank

### GOLDEN FUEL SYSTEM

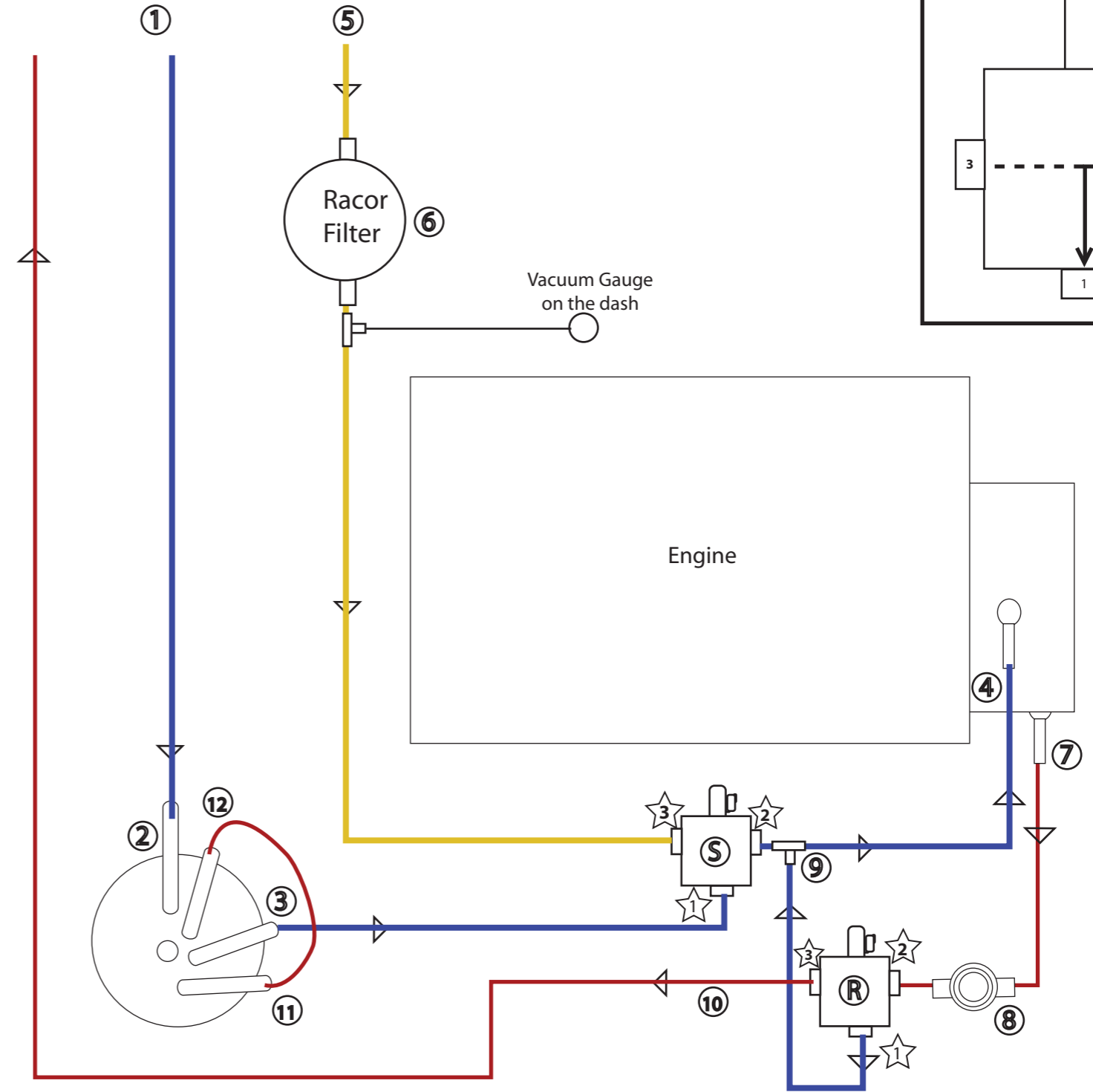

- ① Fuel Pump (located in-tank)
- ② Diesel Supply IN stock fuel filter
- ③ Diesel Supply OUT stock fuel filter to supply valve
- ④ Tandem Pump IN (on the top)
- ⑤ Veggie Supply
- ⑥ Veggie Filter (RACOR AQUABLOC)
- ⑦ RETRUN from Tandem Pump (on the bottom)
- ⑧ Fuel Temperature Sensor
- ⑨ RETURN "LOOP" to the Supply
- ⑩ RETURN back to the veggie tank
- ⑪ loop
- ⑫ loop
- ☆ valve normally open position
- ☆ valve normally closed position
- Ⓢ Supply valve
- Ⓡ Return valve
- ☆ Common Port facing the engine

